

# Linear Motion Only

## XPowerProbe

(XLPP Linear Only Series)

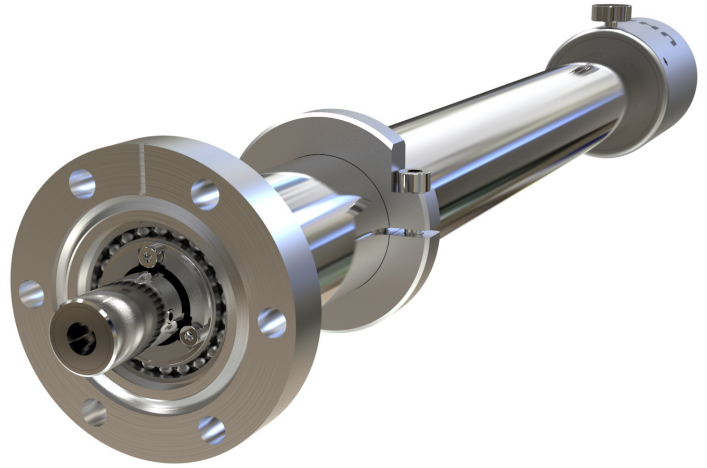

High performance magnetically-coupled linear only motion, designed for sample transfer in UHV applications requiring minimal outgassing. Linear motion of the sample achieved with stroke length from 304mm to 1219mm.

### XLPP KEY ADVANTAGES

- » Unrivalled axial coupling strength
- » Exceptional axial stiffness
- » Minimal outgassing
- » Bakeable to 250°C without removing any components

The XLPP should be selected where only linear motion is required and twisting or turning of the sample would be undesirable.

An anti-rotation system is fitted internally ensuring straight, in-line motion, despite any rotation of the external drive thimble. This removes the need for the unwieldy and bulky external linear guide bars used by other manufacturers and guarantees no rotation during the stroke. The XLPP contains all metal bearings for smooth low friction actuation with minimal outgassing.

The XLPP can be fitted with a bakeable limit switch for the retracted position, aiding system interlocks or fully motorised.

### Comparison to standard PP40

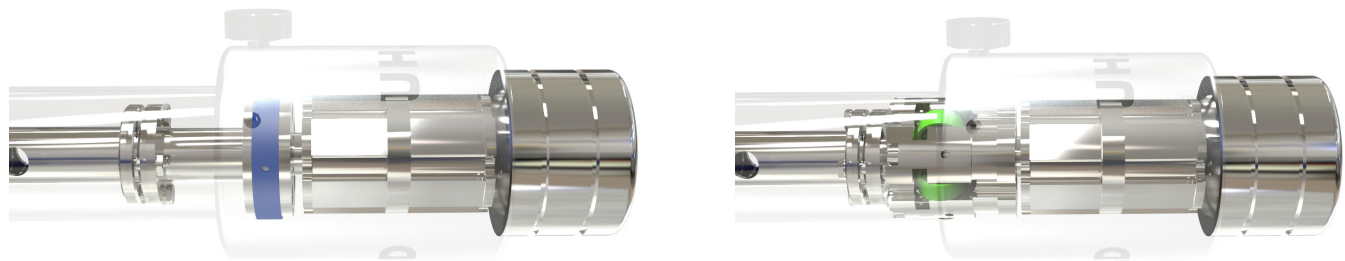

Standard PP40 uses PEEK sliding bearings shown in blue.

XPP40 uses rolling metal bearings shown in green to minimise pressure rise during translation.

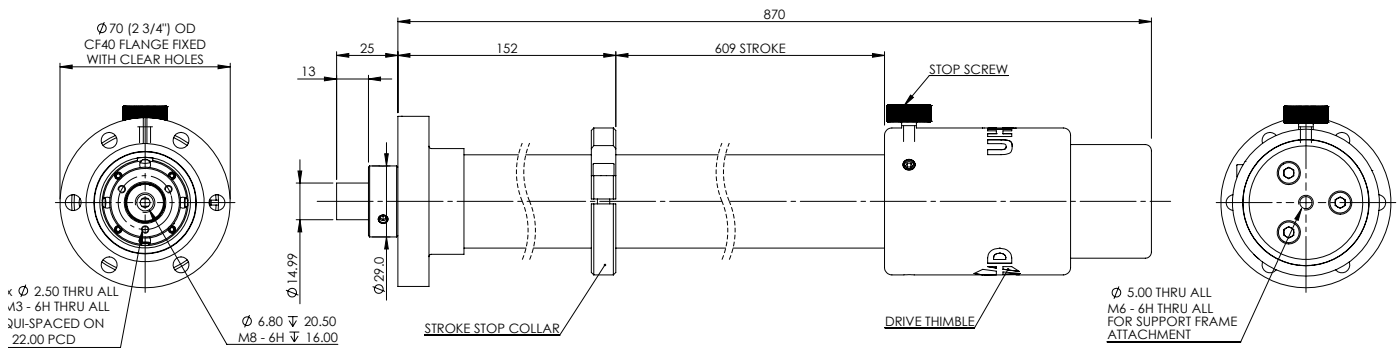

### Example Dimensions (mm) XLPP40-609-H shown

Visit [www.uhvdesign.com](http://www.uhvdesign.com) to configure, view and download 3D models

## XLPP Technical Data

SPECIFICATION	VALUE
System mounting flange size up to 1219mm stroke	CF40 (2 3/4") with clear holes
System mounting flange size 1524mm stroke	CF63 (4 1/2") with clear holes
Magnetic linear breakaway thrust	140 N (31.5 lbs)
Available stroke range	304mm to 1219mm
Output shaft - end interface details	14.99/14.96mm with M8 tapped hole and spigot
Bakeout temperature	250 °C with motor removed
Shaft radial run out	N/A
Shaft radial deviation (linearity) over full stroke	+/- 1 degree
Maximum cantilevered load	20 Nm (177 in-lbs)
Maximum working axial load	90 N (20 lbs)
Retracted position switch - type	Bakeable micro switch wire to WD-020
Stepper motor option	AS4118L1805 with P42H (4:1) gearbox
Stepper motor - motor wiring	UTO socket wired to drawing WD-M-003
Stepper motor option - switches	bakeable limit and home switches with lemo socket wired to diagram WD-002
Stepper motor maximum linear speed	25 mm/second (ballscrew option up to 100mm/second)
Linear resolution per 1/2 step	0.00375 mm
Motor option - leadscrew pitch	6mm

### For more information:

**UHV Design Ltd**  
 Judges House, Lewes Road,  
 Laughton, East Sussex, BN8 6BN, UK  
 T: +44(0)1323 811188  
 E: [sales@uhvdesign.com](mailto:sales@uhvdesign.com)  
[www.uhvdesign.com](http://www.uhvdesign.com)

To find your nearest UHV Design representative please visit [www.uhvdesign.com](http://www.uhvdesign.com) and click 'Contact'.